

Sight Glass Mounts



Sight Glass Mounts Quickly attach tubular proximity sensors to glass and plastic tubes for level detection. Often used in pairs to detect absence or presence of liquids to activate pumps and drains in process control applications.



Features

- Adjusts "on the fly" with visual feedback
- Models for 12, 18 and 30 sensors
- For 9.5mm (3/8") to 44mm (1-3/4") pipes
- Delrin® construction with all stainless steel fasteners

Benefits

- Instantly converts tubular controls to level sensors
- Rapid, "out of tank" level adjustments
- Simple sensor change-out / replacement
- Very secure mounting

Typical Application

Shown below are two Sight Glass mounts attached to a sight tube on a large tank. Each mount holds a capacitive sensor which senses through the glass tube and monitors for the presence of the tank's contents. The bottom sensor turns the pump on and the top sensor turns the pump off. Changing activation points is accomplished simply by sliding the mounts along the sight tube.

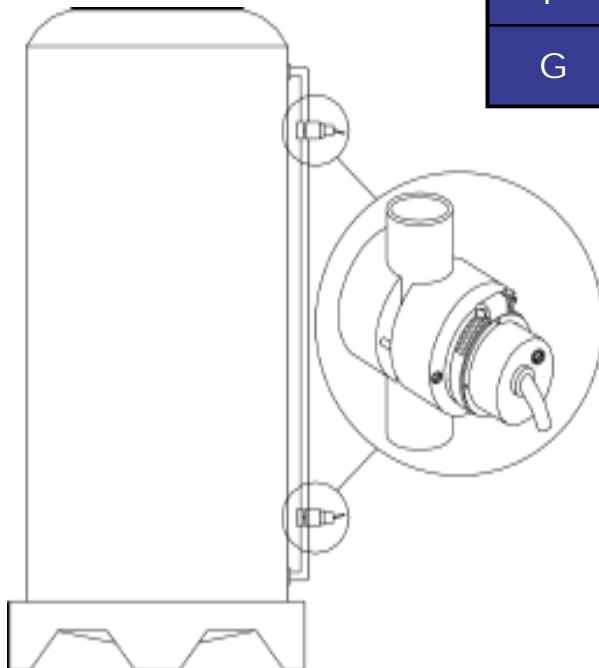

Model	SG-12	SG-18	SG-30	SG-32	SG-34
A	12.1 (0.48)	18.1 (0.71)	30.1 (1.19)	32.1 (1.26)	34.1 (1.34)
B	19.6 (0.77)	25.4 (1.00)	40.9 (1.61)		
C	38.1 (1.50)	43.9 (1.73)	69.9 (2.75)		
D	29.5 (1.16)	38.1 (1.50)	67.8 (2.67)		
E	13.0 (0.51)	15.9 (0.63)	31.8 (1.25)		
F	10.5 (0.42)	11.7 (0.46)	19.1 (0.75)		
G	9.40 to 20.6 (0.37 to 0.81)	14.7 to 28.4 (0.58 to 1.12)	25.4 to 44.5 (1.00 to 1.75)		

